

MÉCANIQUE DE LA NACELLE
SYSTÈME DE ROTATION DES NACELLES INCLUANT UNE BANDE DE ROULEMENT (a), UNE COURONNE D'ENTRAÎNEMENT SCÉLÉE (b), UNE CHAÎNE DE TRANSFERT (c), UN RÉDUCTEUR À ENGRENAGE (d) ET UN SYSTÈME DE PÉDALIER (e).

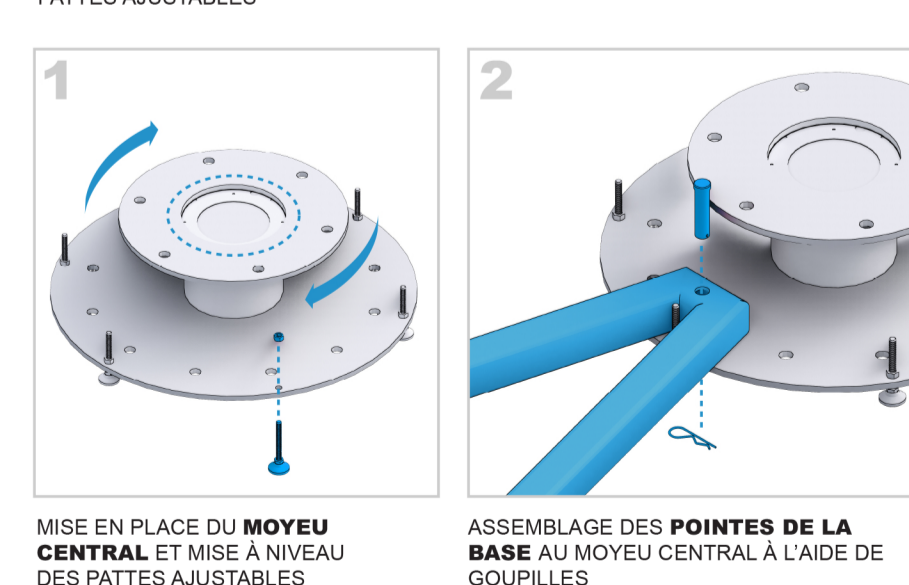

ÉTAPES D'ASSEMBLAGE

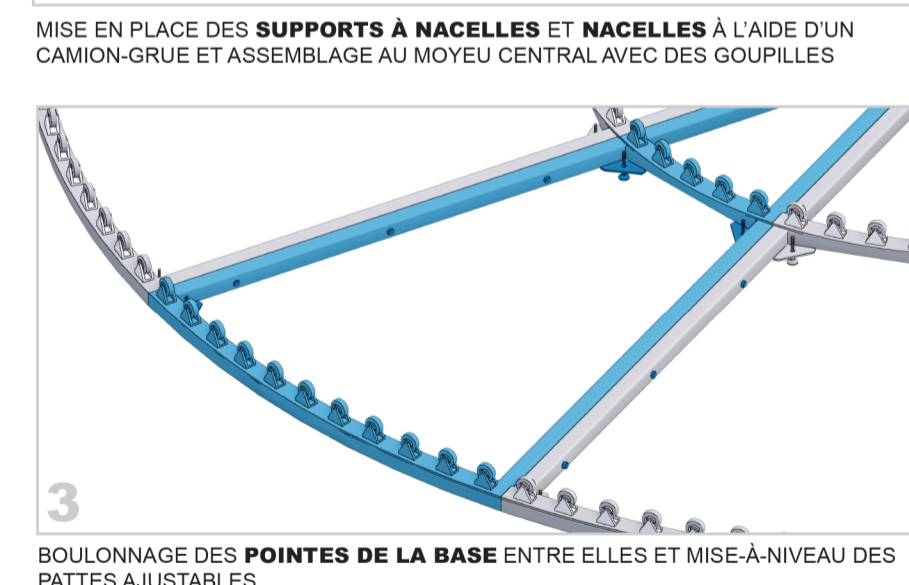
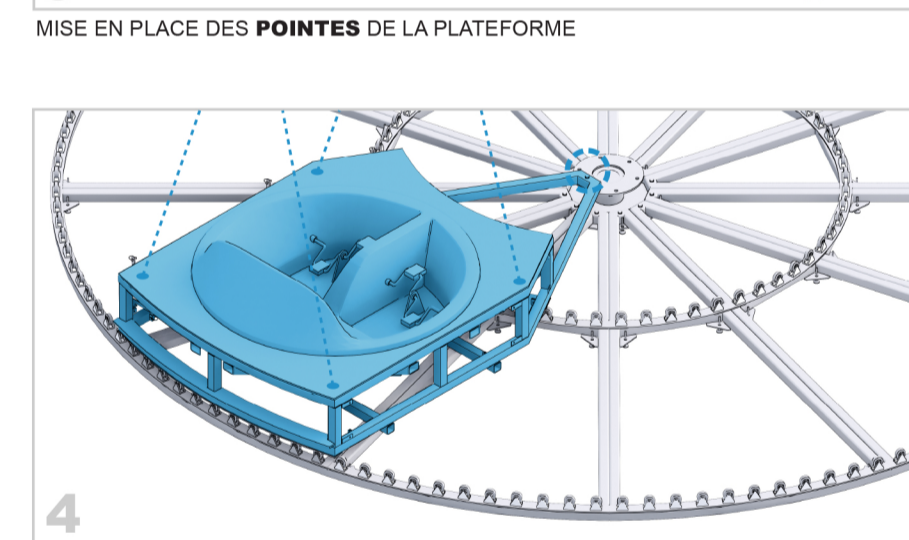
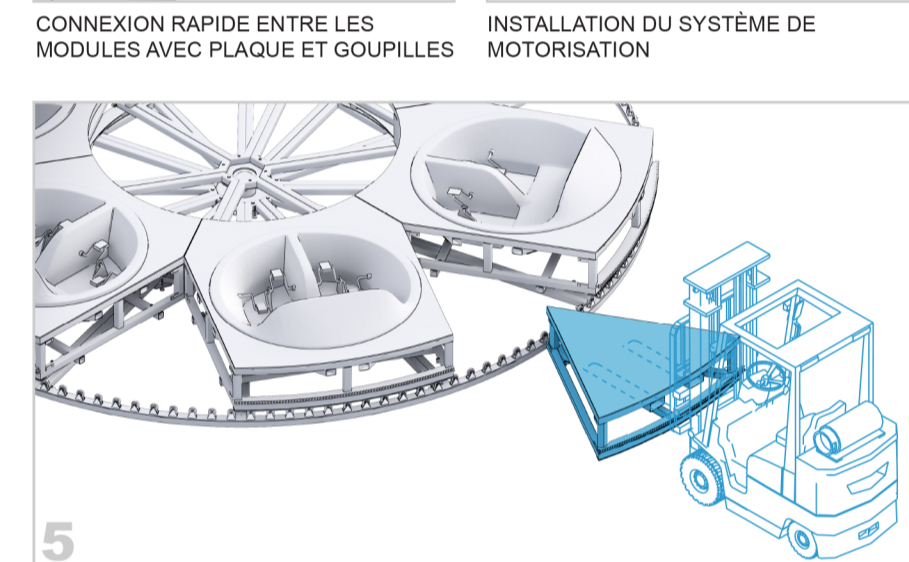
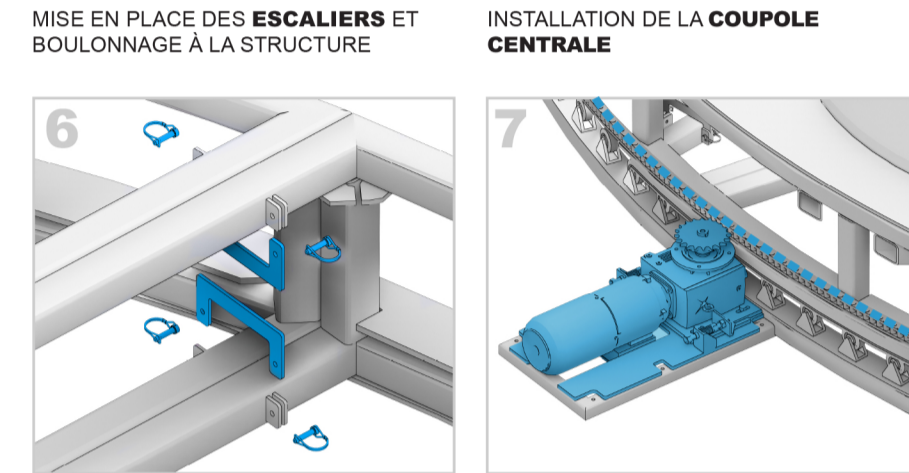
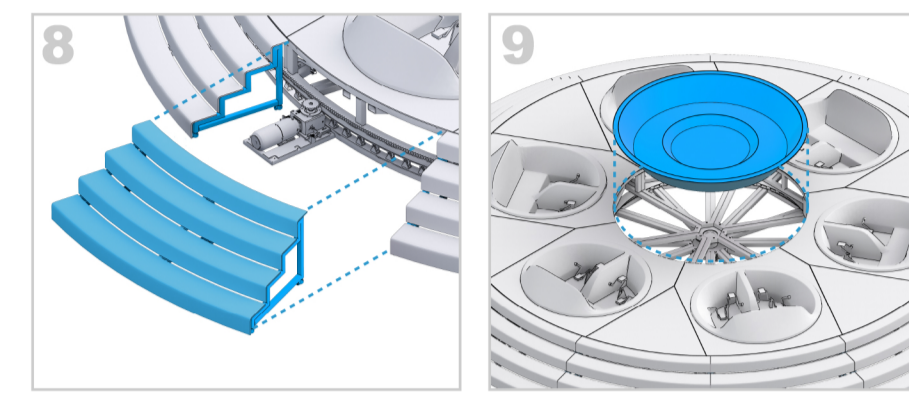

LA FONTAINE
ISOMÉTRIE ÉCLATÉE

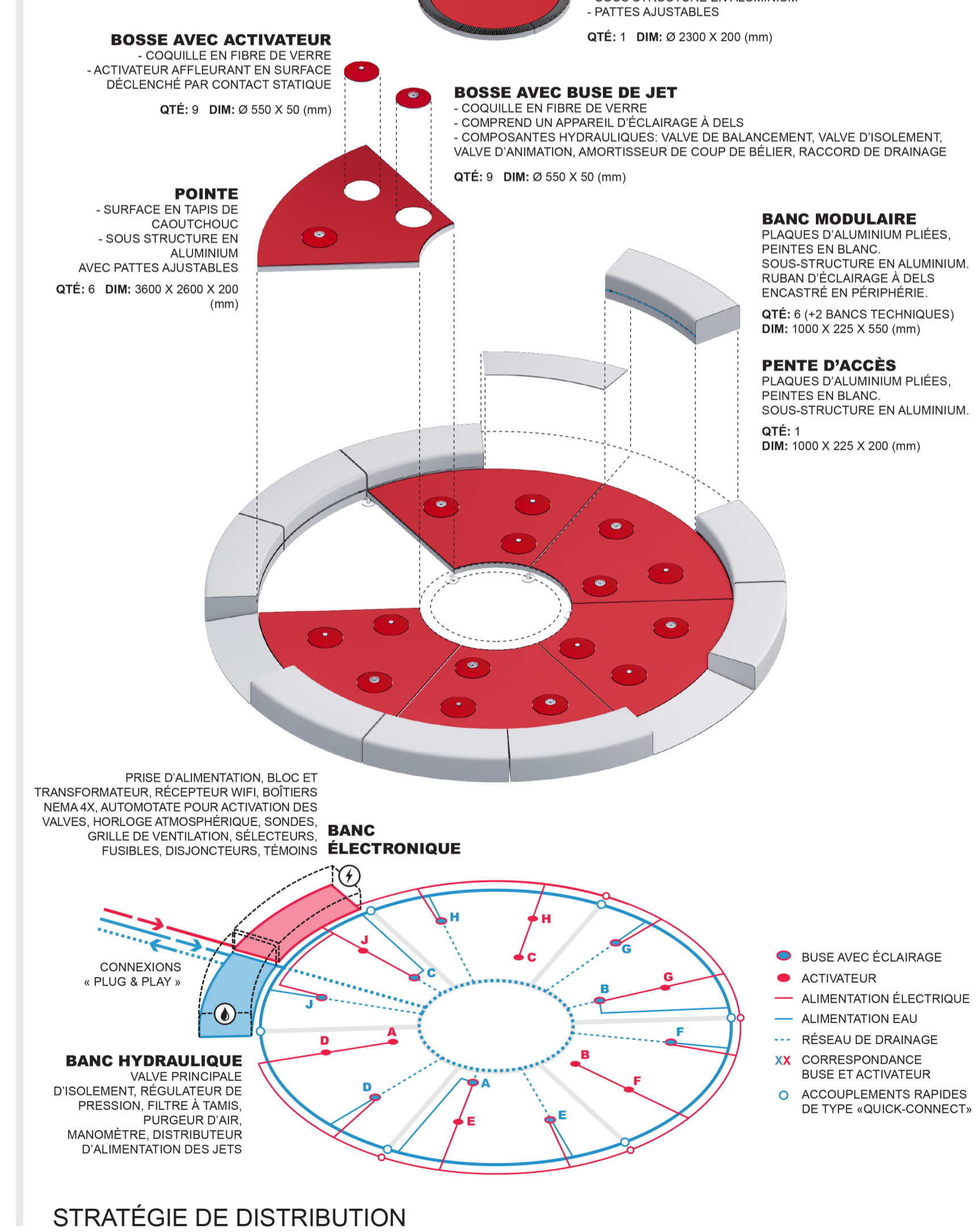

LE MONTICULE
ISOMÉTRIE ÉCLATÉE

